

Ground source heat pump
Geopro RE

Reliable, Finnish quality for large properties



Geopro

Lower heating costs with geothermal energy

Geothermal energy is significantly more cost-efficient overall than many other alternatives for heating. Geothermal energy is suitable for modernisations and renovations where there is a water heating system. The larger the energy need, the greater the benefit offered by geothermal energy. Why not take advantage of this free source of solar energy stored in the ground?

Big energy savings with the Geopro RE ground source heat pump

The Geopro RE is a new ground source heat pump for large properties, which is suitable as a heat source for public buildings, industrial properties, tower blocks and terraced houses, for instance. By connecting pumps in series, heat can easily be produced for large areas. According to usage requirements, the pump can be supplied with a superheater or without. The unit may also be supplied with a subcooler, with the help of which even the last remnants of energy may be utilised, for example, in the pre-heating of domestic water. Thanks to the subcooler, as much as 5% extra free residual heat is available to you.

All connections are made to the rear panel of the unit.

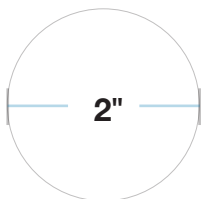

Condenser and evaporator 2"



Subcooler and superheater 1 1/4"



Natural energy

Geothermal energy is a highly sustainable option ecologically. It uses only a small amount of electricity for operating the compressor and circulating water in the collector piping, but it transfers many times this amount as geothermal energy taken from the ground.

Robust quality

The Geopro is made in Finland and is built to last. The pump is virtually maintenance-free, and the minor required servicing tasks are quick and easy. In the new RE model, the same proven components are used as in the other Geopro models. Depending on the model, either one or two high-quality Scroll compressors ensure a long product life and trouble-free operation.

Functional style

The design of the Oilon Geopro RE is practical and stylish in a simple way. Durability, ease of use, good sound-proofing and ease maintenance are qualities that have inspired confidence in customers.

Multiple energy options

The versatility of automatics in the unit also enables other energy sources to be combined to create an effective entity. In addition to geothermal energy, for example solar-energy collectors, oil, gas or pellet heating can be used. The unit will automatically select the energy option that is generated in the cheapest way at any given time.



Oil burners
Bio-oil burners
Gas burners
Bio-gas burners
Pellet burners



Ground source
heat pumps



Air to water
heat pumps



Solar energy collectors



1360 kW

1275 kW

1190 kW

1105 kW

1020 kW

935 kW

850 kW

765 kW

680 kW

595 kW

510 kW

425 kW

340 kW

255 kW

170 kW

85 kW

Multiple thermal-power units

As many as 16 Oilon Geopro RE ground source heat pumps can be connected in parallel. Thus, a heating capacity of more than 1.3 megawatts can be achieved, and this is equivalent to the energy requirements of around 150 detached houses.

Ground source heat pump sizing

The ground source heat pump may be sized up to full capacity or a partial capacity. On partial capacity, the maximum

capacity of the heat pump satisfies around 60–80% of a building's heating requirements. Thus, in practice, the pump will provide 85–98% of the annual energy requirements. On partial capacity setting, the heat pump works for long periods during the heating period, and this reduces the number of times that the compressor is started up and shut down. This saves electricity and conserves the compressor without a reduction in the coefficient of performance. On the full capacity setting, the ground source heat pump is set up according to the maximum capacity requirements of the building, and in practice it is set slightly higher.

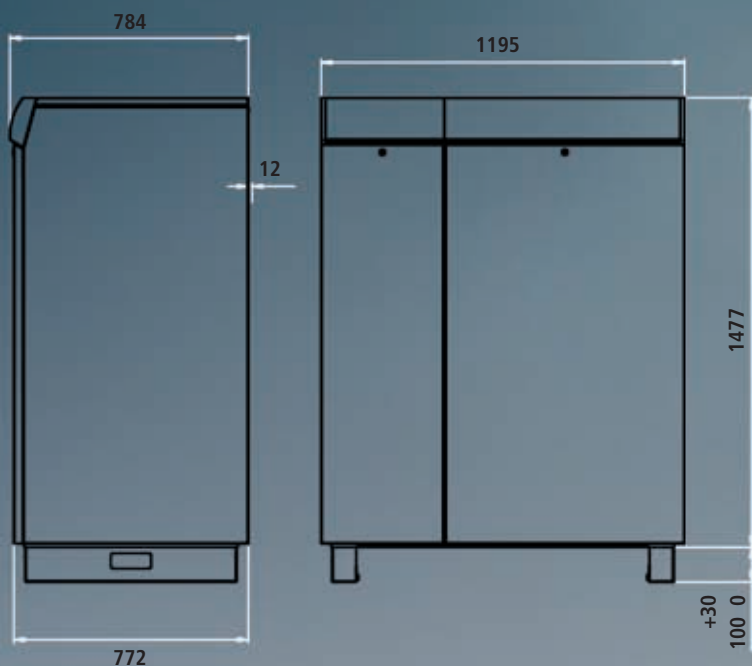

TECHNICAL DATA

Ground source heat pump Geopro RE		35	42	55	70	85
Performance, according to EN 14511 (pumps calculated according to the standard).	Heat from the ground kW	26	31.9	45.8	52.0	63.8
	Compressor electrical power kW	7.9	9.6	13.0	15.8	19.2
	Heating capacity kW	33.9	41.5	58.8	67.8	83.0
Brine 0/35, EN 14511	COP (Coefficient of performance)	4.2	4.2	4.4	4.2	4.2
Temperature	Highest domestic hot water temperature*	58	58	58	58	58
Electrification	Electrical connection	3 / N / PE 400 V 50 Hz				
	Start-up current A**	93	110	71	93	110
	Maximum operating current A**	25	32	2 x 21	2 x 25	2 x 32
Fuse size		35 A	40 A	50 A	63 A	80 A
Refrigerant circuit	Refrigerant	R407C				
	Quantity of refrigerant	7.5 kg	8.7 kg	11.3 kg	14.2 kg	15.8 kg
	Compressor	Scroll				
Heat-pump assembly sizes	Ground circulation in/out	2"	2"	2"	2"	2"
	Water to/from the condenser	2"	2"	2"	2"	2"
	Water to/from the superheater	1 1/4"	1 1/4"	1 1/4"	1 1/4"	1 1/4"
	Water to/from the subcooler	1 1/4"	1 1/4"	1 1/4"	1 1/4"	1 1/4"
Dimensions	mm	height 1,550, width 1,180, depth 780				

* Without superheater

** With a soft starter

OILON HOME OY

P. O. Box 5, 15801 Lahti, Finland

Street address: Tarmontie 4, 15860 Hollola, Finland

Tel. +358 3 85 761, fax +358 3 857 6239, info@oilon.com

oilon[®] Home
www.oilon.com