

Oil, gas and dual fuel burners

Series 6 to 26

Group
2
Capacity
42–400 kW



Burner	Capacity kW	Dimensions in mm						Weight kg
		L1	L2 *)	B1	B2	H1	ø D1	
KP-6	42 - 120	310	105	210	180	230	90	17
KP-6 L	42 - 120	310	105	210	180	230	90	17
KP-6 LH	42 - 120	400	105	210	180	255	90	19
KP-6-2	71 - 140	310	110	210	180	230	100	17
KP-6 H-2	71 - 190	400	110	210	180	255	100	19
KP-24	83 - 180	400	115	260	200	270	125	24
KP-24 H	83 - 215	440	115	260	200	270	125	26
KP-26	95 - 240	400	140	260	200	270	140	24
KP-26 H	95 - 350	440	140	260	200	270	140	26
KP-26 H-II	95 - 350	440	140	260	200	270	140	26
KP-24 L	83 - 180	530	115	260	200	380	125	35
KP-24 LH	83 - 215	530	115	260	200	380	125	37
KP-26 L	95 - 240	530	140	260	200	380	140	35
KP-26 LH	95 - 350	530	140	260	200	380	140	37
KP-26 LH-II	95 - 350	530	140	260	200	380	140	37
GP-6.10	45 - 120	310	110	210	180	230	95	20
GP-6.20	60 - 160	310	110	210	180	230	100	20
GP-6.10 H	45 - 120	400	110	210	180	255	95	22
GP-6.20 H	60 - 160	400	110	210	180	255	100	22
GP-26.10	80 - 270	400	140	220	200	270	140	30
GP-26.10 H	80 - 270	440	140	220	200	270	140	35
GP-26.21 H	120 - 400	600	170	220	200	270	158	35
GKP-6.11	45 - 120	400	110	210	180	255	95	23
GKP-6.21	71 - 160	400	110	210	180	255	100	23
GKP-6.11 H	45 - 120	500	110	210	180	255	95	25
GKP-6.21 H	71 - 160	500	110	210	180	255	100	25
GKP-26.11 H	95 - 270	600	140	260	200	270	140	35
GKP-26.21 H	120 - 400	600	170	260	200	270	158	35

*) longer burner heads also available at intervals of 50 mm

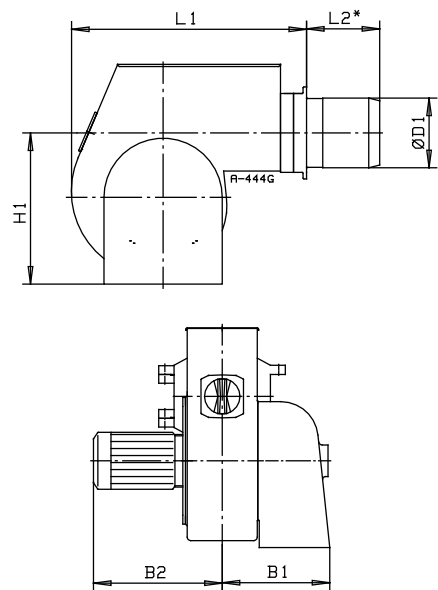

DESCRIPTION

The Oilon 6, 24 and 26 burners are fully automatic in operation. The suitable burner type can be selected from the series of light fuel oil burners, gas burners or dual fuel burners. In their design, special consideration has been given to economic and ecological factors, safety and easy servicing. The gas burners comply with standard EN 676, oil burners with EN 267 and EN 230 and dual fuel burners with all the above mentioned standards and they are EU type tested. All burners are adjusted and tested at the factory. The correct choice of material and strict quality control guarantee high quality. Due to tested components, precision burner heads and clear and simple structure, the burners ignite easily and the flame remains steady and sootless even in the most difficult circumstances. Its high efficiency lasts year after year.

CONSTRUCTION

These burners are of monoblock type. The burner casing includes single-phase motor, which drives the combustion air fan and the oil pump. The burners are equipped with one or two separately controlled nozzle. Control for burner functions is built-in in the casing. The burners are mounted on a hinged flange that can be turned either to the left or to the right. In standard delivery the gas and dual fuel burners turn to the left. The hinged flange makes it easier to service the burner head, ignition electrodes and nozzles.

APPLICATIONS

The burners can be fitted on hot water boilers, on steam boilers or on air heaters. They are suitable for use in boilers with either high or low combustion chamber pressure. The burners are intended for use in covered areas.

OILON OY

Address P.O. Box 5, FIN-15801 LAHTI, FINLAND
Metsä-Pietilänkatu 1, 15800 LAHTI, FINLAND
Tel. +358 3 85 761
Fax +358 3 857 6239
E-mail info@oilon.com
www.oilon.com

FUELS

In the different burner types, the following fuels can be used:

KP models: light fuel oil, viscosity of 4 - 12 mm²/s at +20 °C

KP-24L...KP-26LH-II models: with mass preheater light fuel oil, viscosity up to 15 mm²/s at +20 °C

GP models: -natural gas, gases of the 2nd family, groups H and E (equipment category I_{2R})
-LPG, gases of the 3rd family, group P (equipment category I_{3R})

GKP models: the dual fuel burners operate on the abovementioned oil and gases. Other types of fuel on request only.

BURNER REGULATION

Depending on the fuel and the burner type the following alternatives apply when choosing the capacity regulation:

- single-stage
- two-stage, H.

GAS VALVES

The Oilon GP and GKP gas burners are supplied with gas valves, which are selected according to the gas pressure and to meet the requirement of the customer.

FLAME MONITORING

All models are supplied with automatic flame monitoring. The control unit sequences the burner operation automatically.

CONTROL PANEL

All burner types can be equipped with a separate control panel.

This specification is subject to alternation without notice.