

oilon[®]

Power Plant and Process Burners

Group

6

Capacity
2-63 MW



Power plants

District heating
plants

Pulp and paper

Chemical industry

Metallurgic
processes

Municipal waste
incineration

Hazardous waste
incineration

Odorous gas
incineration

Fluidized bed
boilers

Recovery boilers

Marine boilers

Steam boilers

Hot water boilers

Thermal oil boilers

Process furnaces

Hot air generators

Other applications



Oilon burner expertise for power plants and industrial processes

Oilon Energy Oy specializes in power plant and process burners which are capable of being used in several different plants and applications. The know-how of valve units, pumping stations and burner automation enables Oilon to deliver complete combustion systems. In group 6, the atomizing of fuel is done by means of steam or compressed air. The burners are duo-block type, i.e. the combustion air is provided by a separate blower, which can also be included in the Oilon delivery.

Benefits to plant owner

Oilon's experience of burners and auxiliary equipment dates back from 1961. The main objectives of research and development involve high efficiency, reliable operation, environmentally friendly combustion and low emissions. The fine tuning of the combustion process is realized by automation system giving the right kind of controls, based also on the long experience of Oilon. This combination of expertise guarantees the optimal performance and availability of the plant.



Pulp and paper



Hazardous and municipal waste incineration

Applications

Oilon's burner technology is utilized in various power plants and industrial processes, such as steam and hot water boilers, district heating plants, hazardous and municipal waste incineration, pulp and paper, metallurgic processes, aluminium production, hot air generators etc.

Fuels

In addition to standard, commercially available liquid and gaseous fuels, Oilon has experience in combustion of numerous other fuels. These include a wide variety of bio and process fuels as well as wastes. All Oilon burner families have a prearrangement to operate as multi-fuel burners in which liquids and gases can be combusted either separately or simultaneously.



Metallurgic processes

World-wide expertise

Oilon has world-wide experience and equipment deliveries to every continent. Local legislation and standards will be observed and followed. In case of additional emission requirements coming for example from environmental permitting, the equipment and processes will be designed to meet those. The experts in Oilon know the circumstances in different plants and have competence to support in decisions concerning combustion.



Aluminium production

LENOX low NO_x burners

Lenox is designed for power plant boilers fulfilling the stringent emission requirements. This achievement of technology is based on staged combustion. Fuel is lead into different zones of the flame. Combustion air is divided into individually controlled chambers in wind box and directed also in stages to the flame. These fuel and air flows cause optimal air envelopes inside and around the flame resulting in long residence time and low emissions. If the requirements of emission levels are very demanding, flue gas recirculation is an option to Lenox.

Maximum pressure loss 2.5 kPa. *)

- KT...L = light fuel oil burner
- RT...L = heavy fuel oil burner
- GT...L = gas burner
- GKT...L = gas/light fuel oil burner
- GRT...L = gas/heavy fuel oil burner



K1 (type GT-...L)
K2 (type RT-...L, KT-...L)
K3 (type GRT-...L, GKT-...L)

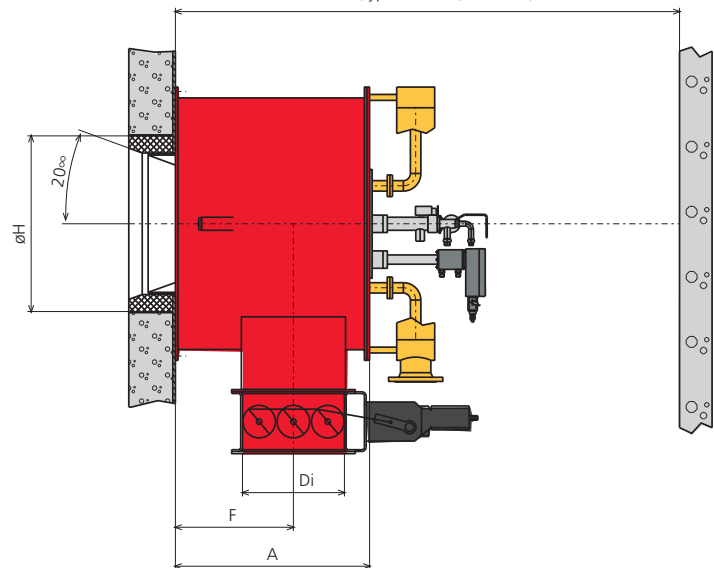
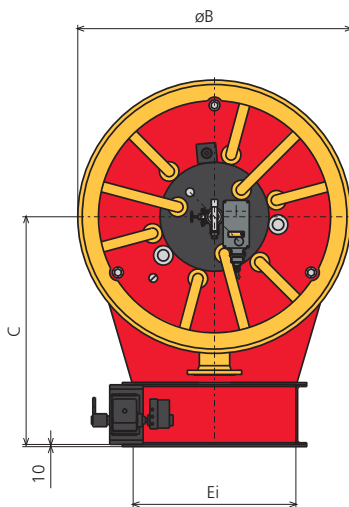

Burner	Nominal capacity *) MW	A mm	B mm	C mm	Di mm	Ei mm	F mm	H Typical mm	K1 mm	K2 mm	K3 mm
GT/RT/KT/GRT/GKT -5L	0.9 - 4.5	535	730	910	260	425	301	500	2400	2650	2650
GT/RT/KT/GRT/GKT -8L	1.4 - 7.0	640	890	970	310	500	381	590	2500	2750	2750
GT/RT/KT/GRT/GKT -12L	2.2 - 11.0	775	1090	1000	395	625	464	700	2650	2900	2900
GT/RT/KT/GRT/GKT -18L	3.2 - 16.0	895	1260	1050	470	750	544	810	2900	3100	3100
GT/RT/KT/GRT/GKT -25L	4.4 - 22.0	1030	1460	1500	530	900	649	940	3250	3350	3350
GT/RT/KT/GRT/GKT -35L	6.2 - 31.0	1175	1680	1600	630	1025	744	1070	3450	3800	3800
GT/RT/KT/GRT/GKT -50L	9.0 - 45.0	1390	2000	1700	785	1200	882	1270	3900	4200	4200
GT/RT/KT/GRT/GKT -70L	12.6 - 63.0	1590	2300	1875	950	1450	999	1430	4200	4650	4650

*) Valid, when combustion air temperature is +35°C, λ=1,17 and ambient air pressure 1,013 bar a.

S-burners for a wide range of applications

S-burner is typically used in hot water and steam boilers, but is suitable also in various further applications. The amount and ratio of primary and secondary air can be adjusted. Secondary air is guided through adjustable air vanes, which enables the formation of the desired flame shape and thus matching optimally to the furnace dimensions. Additionally, the adjustability contributes to achieving the required emission levels in different furnace sizes and forms. By request, S-burner is capable to be provided with single or dual-fuel liquid lance, gas lance and gas ring.

Maximum pressure loss 3.5 kPa. *)

- KT...S = light fuel oil burner
- RT...S = heavy fuel oil burner
- GT...S = gas burner
- GKT...S = gas/light fuel oil burner
- GRT...S = gas/heavy fuel oil burner

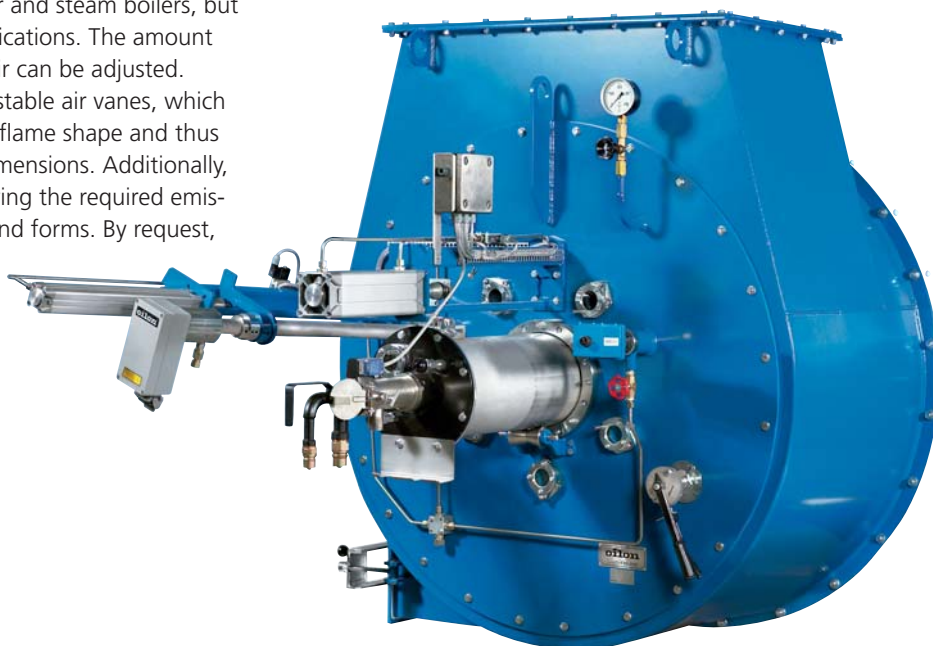

K1 (type GT...S)
K2 (type RT...S, KT...S)
K3 (type GRT...S, GKT...S)

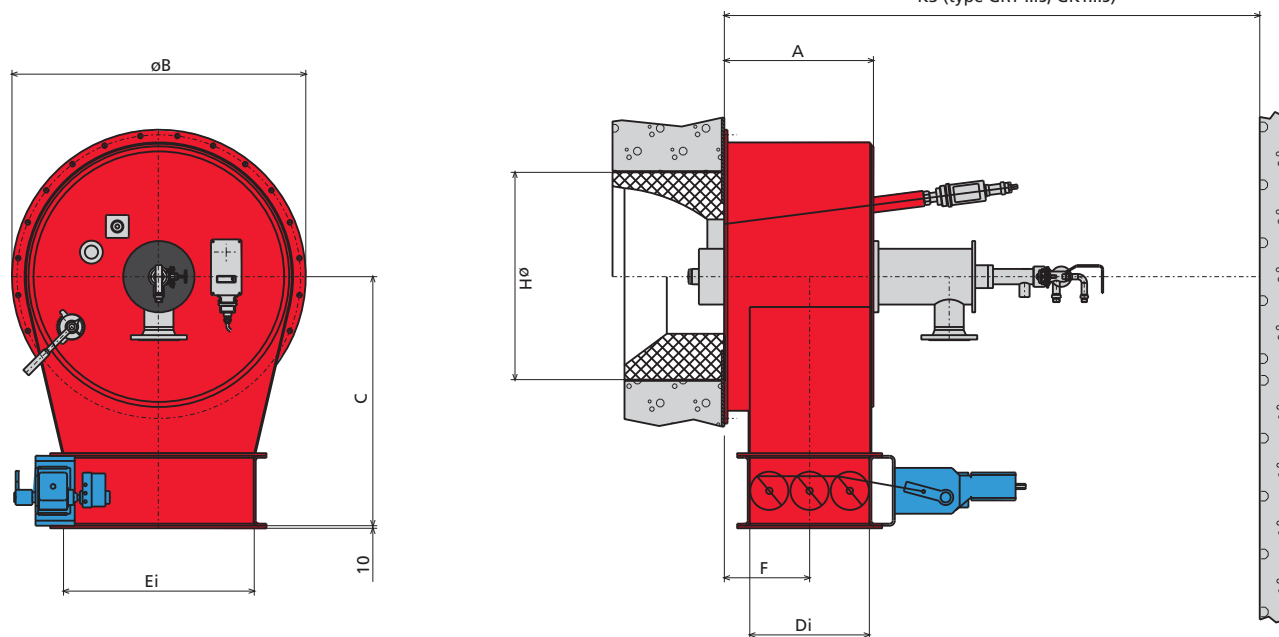

Burner	Nominal capacity *) MW	A mm	B mm	C mm	Di mm	Ei mm	F mm	H Typical mm	K1 mm	K2 mm	K3 mm
GT/RT/KT/GRT/GKT -5S	0.9 - 4.5	390	735	740	260	425	244	520	1700	2100	2700
GT/RT/KT/GRT/GKT -8S	1.4 - 7.0	460	865	795	310	500	289	600	1900	2300	2900
GT/RT/KT/GRT/GKT -12S	2.2 - 11.0	540	995	865	395	625	327	710	2100	2500	3300
GT/RT/KT/GRT/GKT -18S	3.2 - 16.0	586	1155	980	470	750	335	820	2700	2900	3500
GT/RT/KT/GRT/GKT -25S	4.4 - 22.0	739	1315	1100	530	900	454	940	2600	2900	4000
GT/RT/KT/GRT/GKT -35S	6.2 - 31.0	853	1610	1250	630	1025	530	1030	2900	3500	4300
GT/RT/KT/GRT/GKT -50S	9.0 - 45.0	1024	1750	1300	785	1200	610	1220	3250	3500	4650

*) Valid, when combustion air temperature is +35°C, λ=1,17 and ambient air pressure 1,013 bar a.

K-burners for various processes

K-burner is the right choice for many different types of industrial processes, for example in hazardous waste and municipal waste incineration plants. The combustion air inlet is located eccentric on one side of the burner guiding the combustion air tangentially to the wind box, which causes a strong swirl and stable flame. The burner construction is designed for heavy duty operation to guarantee good availability in extreme process conditions. K-burner can be equipped with several lances according to the number of different fuels.

Maximum pressure loss 3.5 kPa. *)

- KT...K = light fuel oil burner
- RT...K = heavy fuel oil burner
- GT...K = gas burner
- GKT...K = gas/light fuel oil burner
- GRT...K = gas/heavy fuel oil burner

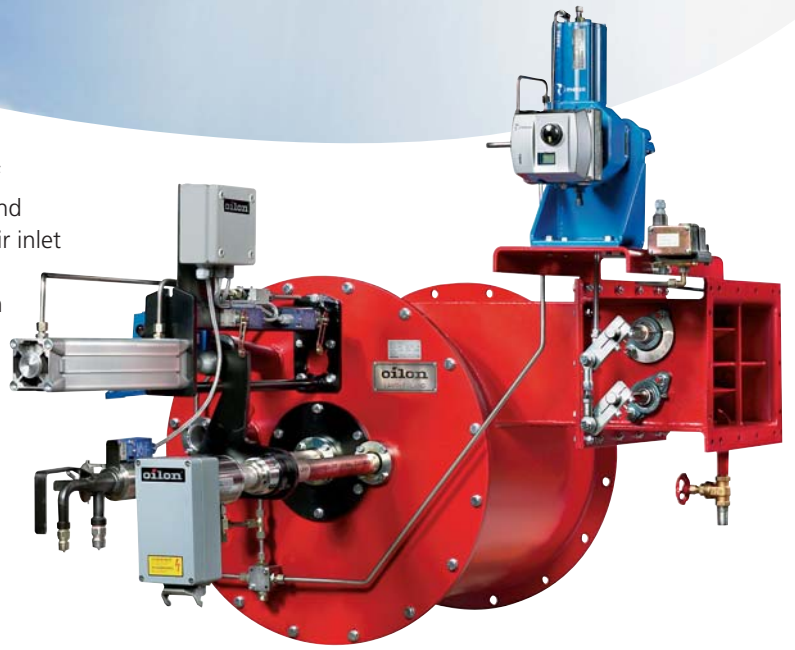

K1 (type GT...K)
K2 (type RT...K, KT...K)
K3 (type GRT...K, GKT...K)

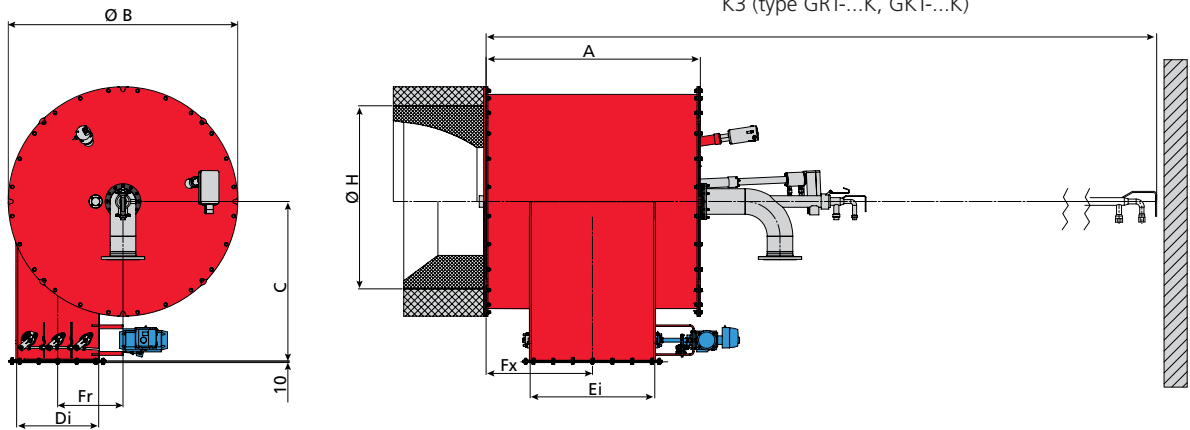

Burner	Nominal capacity *) MW	A mm	B mm	C mm	Di mm	Ei mm	Fx mm	Fr mm	H Typical mm	K1 mm	K2 mm	K3 mm
GT/RT/KT/GRT/GKT -3K	0.5 - 2.7	430	520	520	230	155	210	128	500	2050	2400	2900
GT/RT/KT/GRT/GKT -5K	0.9 - 4.5	550	640	580	295	190	270	170	580	2150	2500	3100
GT/RT/KT/GRT/GKT -8K	1.4 - 7.0	690	780	710	375	250	340	210	670	2400	2700	3300
GT/RT/KT/GRT/GKT -12K	2.2 - 11.0	840	930	725	455	305	415	258	770	2800	2950	3550
GT/RT/KT/GRT/GKT -18K	3.2 - 16.0	1020	1110	815	555	370	505	315	900	3200	3500	4300
GT/RT/KT/GRT/GKT -25K	4.4 - 22.0	1200	1290	905	675	450	595	365	1030	3700	3900	4900
GT/RT/KT/GRT/GKT -35K	6.2 - 31.0	1410	1510	1050	820	540	700	430	1170	4100	4500	5500

*) Valid, when combustion air temperature is +35°C, λ=1,17 and ambient air pressure 1,013 bar a.

Lance burners especially for fluidized bed boilers

Lance burner presents technology to different demanding industrial purposes, for example as start-up and support burner in fluidized bed boilers. It is essential, that the parts will tolerate the effects of the sand bed. This is achieved in lance burner by optimized cleaning and cooling air flow through the burner. When the burner is stand-by, the critical parts will be retracted automatically. The small diameter of the lance burner allows to minimize burner openings on the boiler walls.

Pressure loss is from 2,5 kPa upwards depending on the circumstances and will be determined case by case.

- KL-... = light fuel oil burner
- RL-... = heavy fuel oil burner
- GL-... = gas burner
- GKL-... = gas/light fuel oil burner
- GRL-... = gas/heavy fuel oil burner

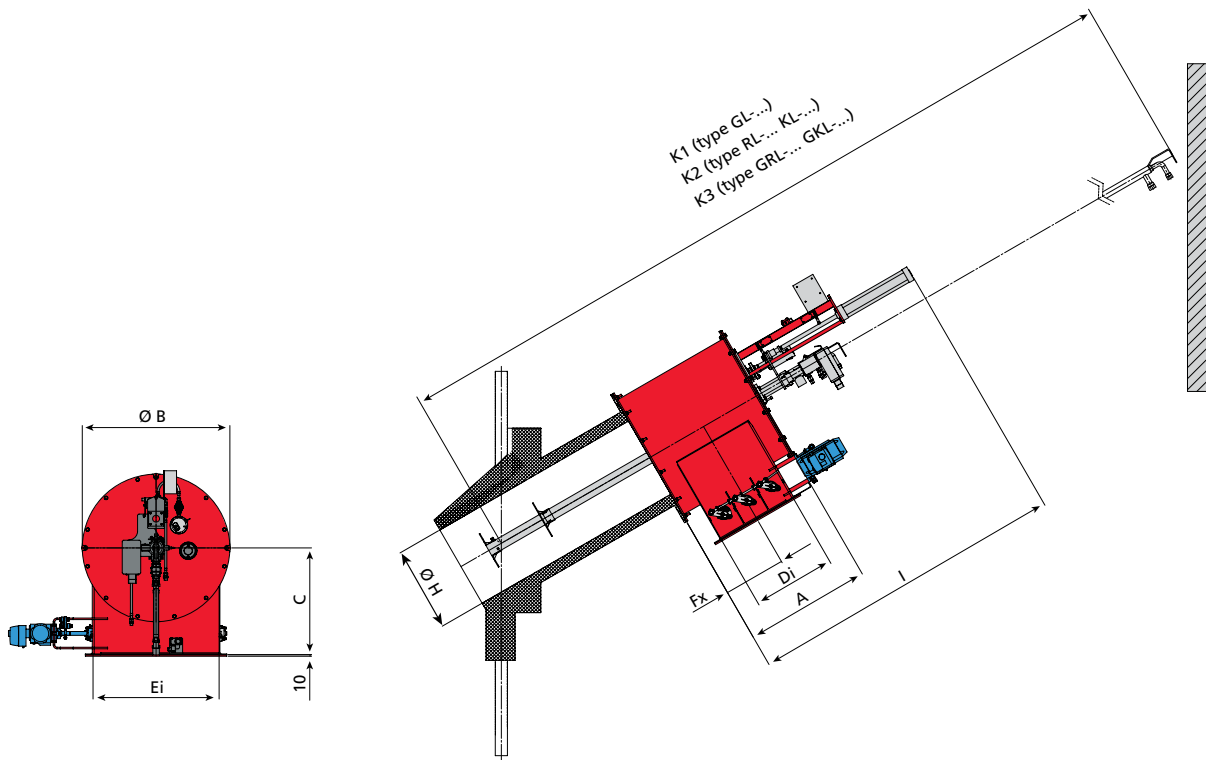
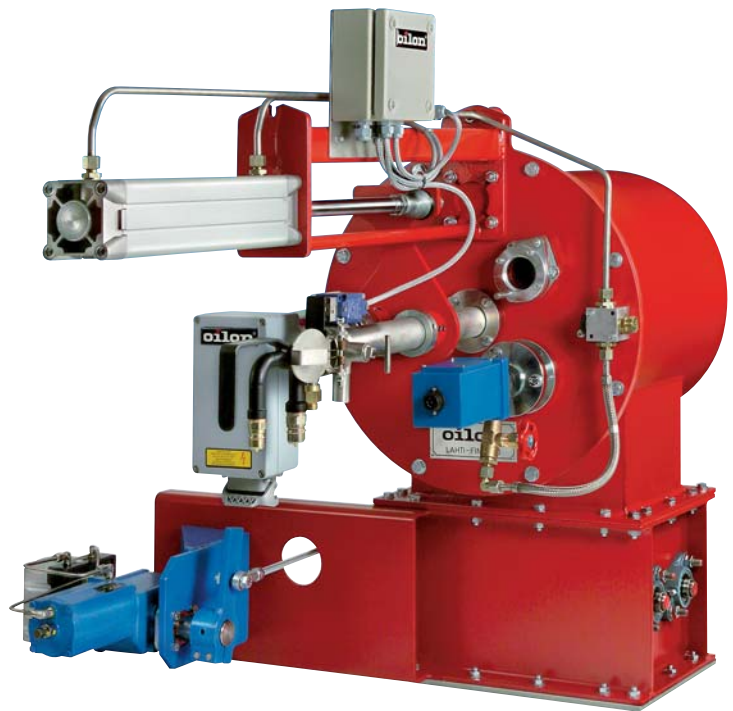

Burner	Nominal capacity *) MW	A mm	B mm	C mm	Di mm	Ei mm	Fx mm	H Typical mm	I mm	K1 mm	K2 mm	K3 mm
GL/RL/KL -250	1.6 - 6.5	550	550	515	250	375	270	250	1603	3500	3800	N.A.
GL/RL/KL/GRL/GKL-350	3.1 - 12.5	580	660	580	370	555	280	350	1623	4000	4500	4900
GL/RL/KL/GRL/GKL -450	5.3 - 21.0	720	810	595	450	675	355	450	1982	4700	5100	5600
GL/RL/KL/GRL/GKL -550	7.8 - 31.0	820	960	695	540	820	405	550	2082	5300	5700	6200

*) Valid, when combustion air temperature is +35°C, λ=0,8 and ambient air pressure 1,013 bar a.

Auxiliary equipment

Correctly dimensioned and designed auxiliary equipment is essential to guarantee optimal performance of the burner. The right instruments, piping materials and process values are chosen on the basis of long experience. All the equipment is assembled and tested at factory and includes the necessary wiring and instrument piping.

Valve units for process gases

The nature and amount of process gases vary considerably depending on the process in question. Corrosive gases, demanding conditions and surroundings etc. are taken into account.

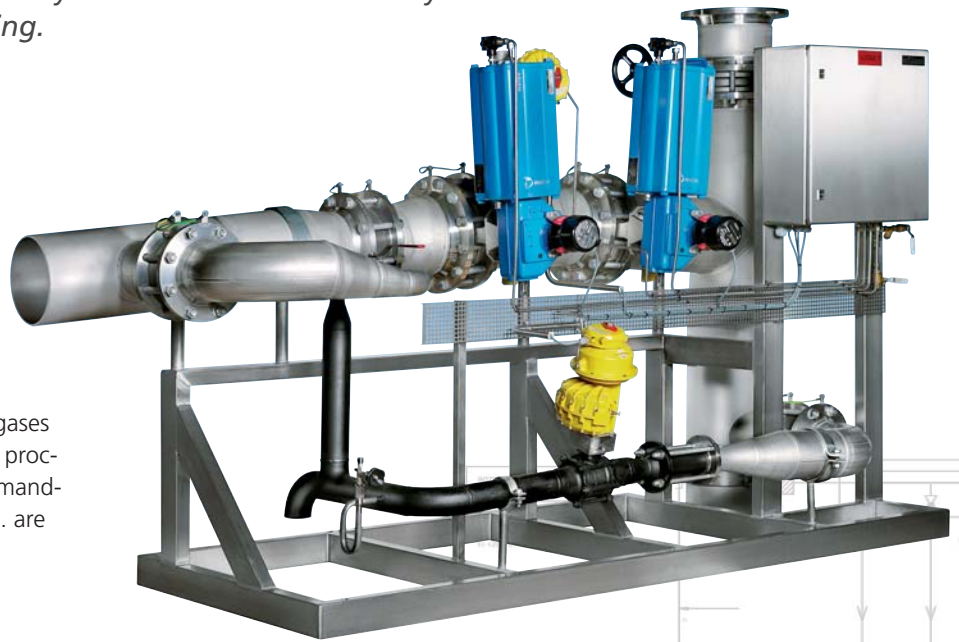

Valve units for natural gas

The capacity of shut-off valve units varies in a range of 200-6500 m³n/h/burner. Filtering, measuring and controlling unit can be individual for each burner. The multi-burner installations, however, can be provided with a unit common for all burners or burner groups.

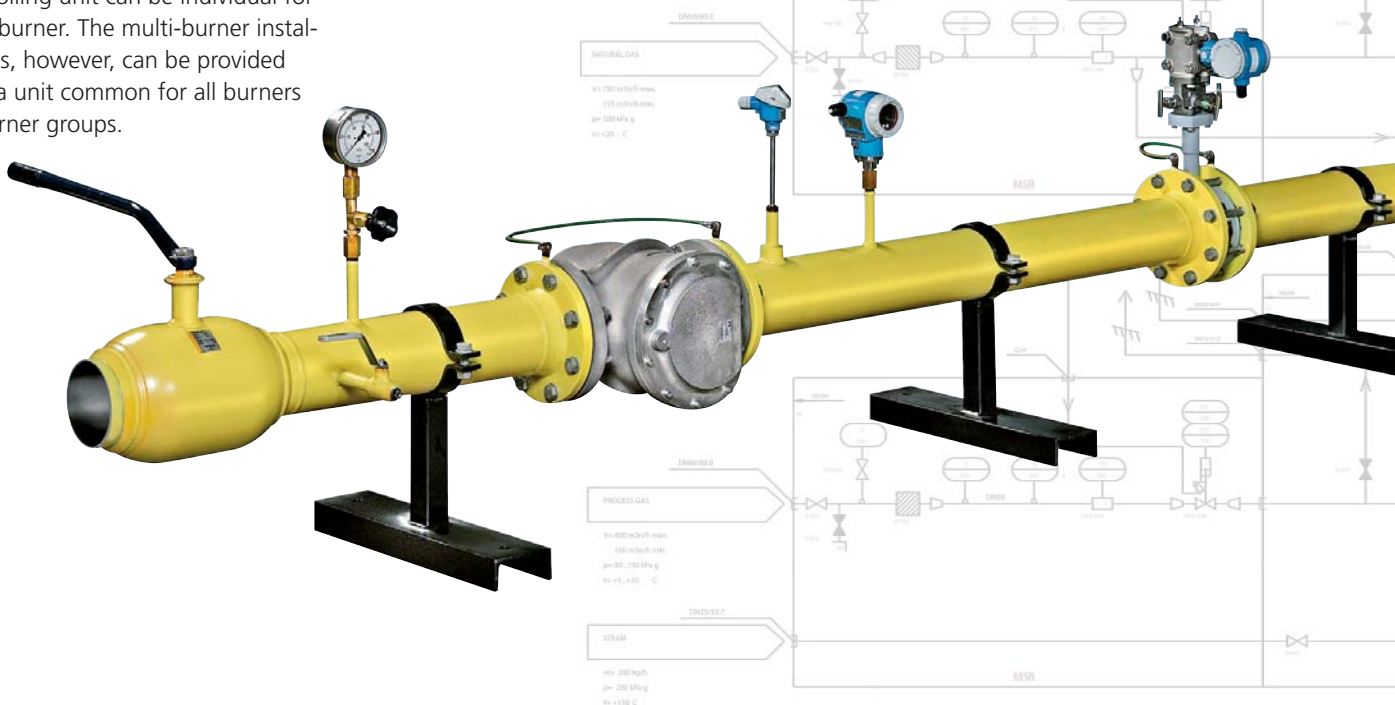

ERDING 3
NATURAL GAS
V₀ 700 m³/h max.
120 m³/h min.
p=100 kPa g
t₀ <+20 °C

ERDING 3
PROCESS GAS
V₀ 400 m³/h max.
100 m³/h min.
p=50...150 kPa g
t₀ <+150 °C

ERDING 3
STEAM
m³ 200 kg/h
p=200 kPa g
t₀ <+150 °C



Rack of three shut-off valve units.

Valve units for oils and other liquid fuels

The shut-off valve unit range covers capacities 150-6000 kg/h/burner. Units can be assembled into one common rack. It is also possible to combine several different fuels.

Oil pumping units

The pumping units include filtering, pumping and pre-heating functions, according to the need. In order to reach high availability, the standard solution is realized with two identical lines. In case of high viscosity, the fuel will be heated up to the correct viscosity by means of steam. For the cold start-up of the plant the pumping units can be equipped with electrical heat exchanger.

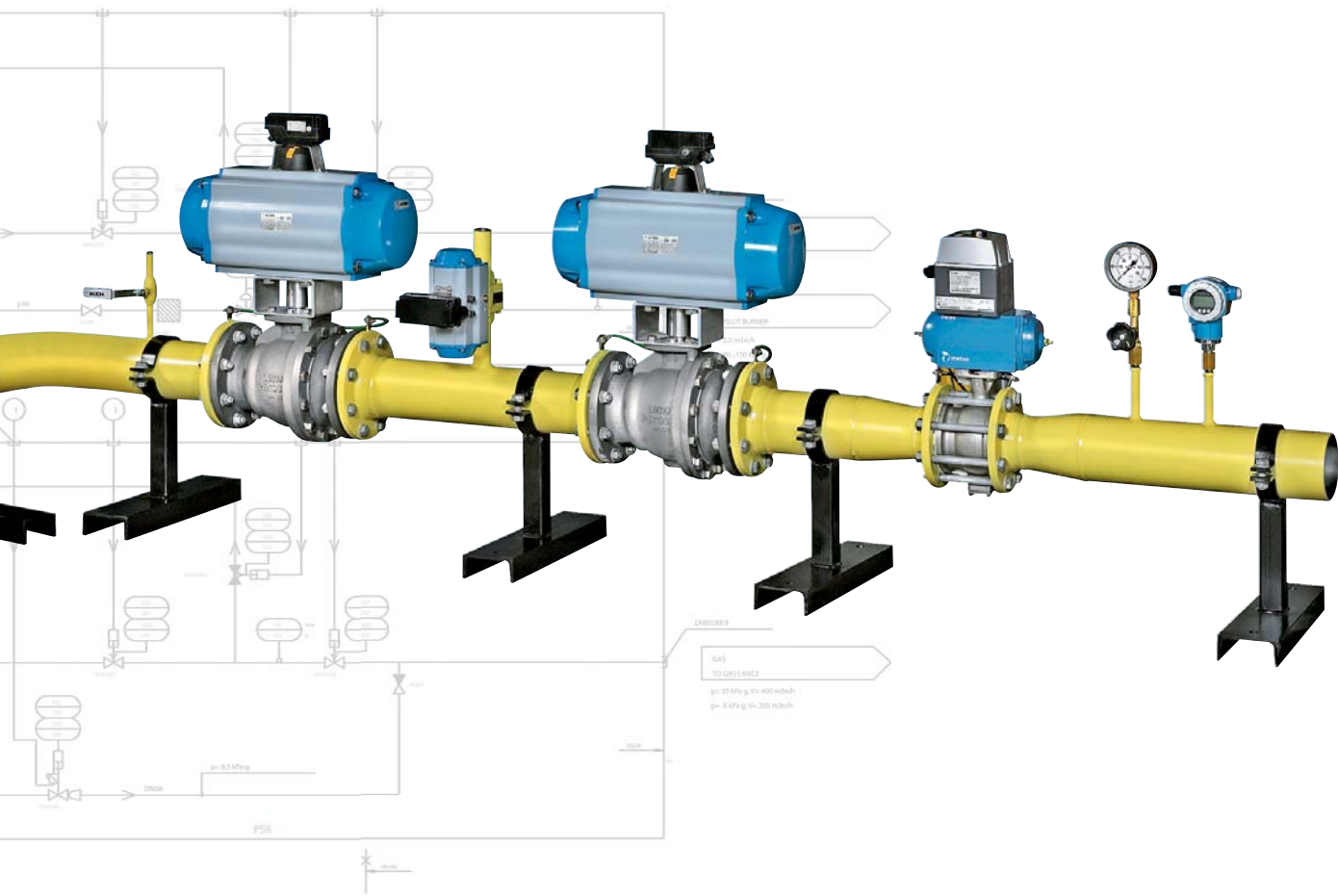

Burner management systems

Oilon has a long experience in designing and manufacturing Burner Management Systems (BMS) to combustion processes. BMS of Oilon utilize optimized controls ensuring the right sequence and fine tuned timing. Consequently, the optimized performance of the combustion means high efficiency and low emissions.

For typical solutions there are standard BMS packages available and for each specific requirement customized systems are worked out. The extent of the system is to be agreed case by case. Normally BMS will be implemented in the main control system of the Plant (DCS). BMS can be based on Programmable Logic Control (PLC) or control relay system. Safety and availability are in important role while designing and realizing an automation system. The right safety level and the need for redundant system will be determined to meet the requirements of the whole process. Every BMS is factory tested (FAT) to guarantee smooth and fast start-up of the combustion system in the plant.



BMS with touch panel for four burners.



BMS safety devices.

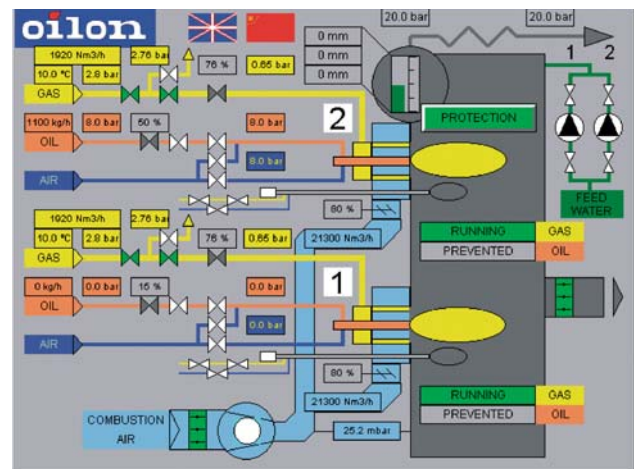

Touch panel screen for combustion system.



Oilon invests in product development and research. A modern product development centre meeting all European standards enables us to perform a wide range of combustion tests and accurate oil and gas measurements.

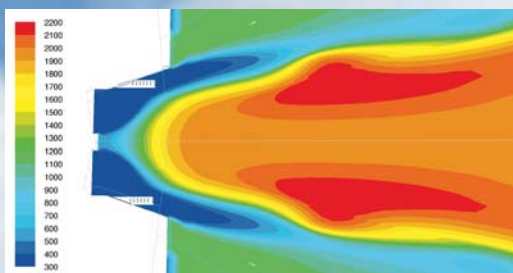

Computational fluid dynamics (CFD) is an essential part of our research and product development. 3D-design and CFD support each other in making decisions on the optimal burner structures. Flow profiles and pressure losses of combustion air, emission levels and temperature distribution in the furnace can also be determined.

OILON ENERGY OY

Metsä-Pietilänkatu 1
P.O. Box 5
FI-15801 Lahti, Finland
Tel. +358 3 85 761
Fax +358 3 857 6277
info@oilon.com